

PRODUCT DATA SHEET
R2 AMP, R2 AMG ROLLING GRILLES

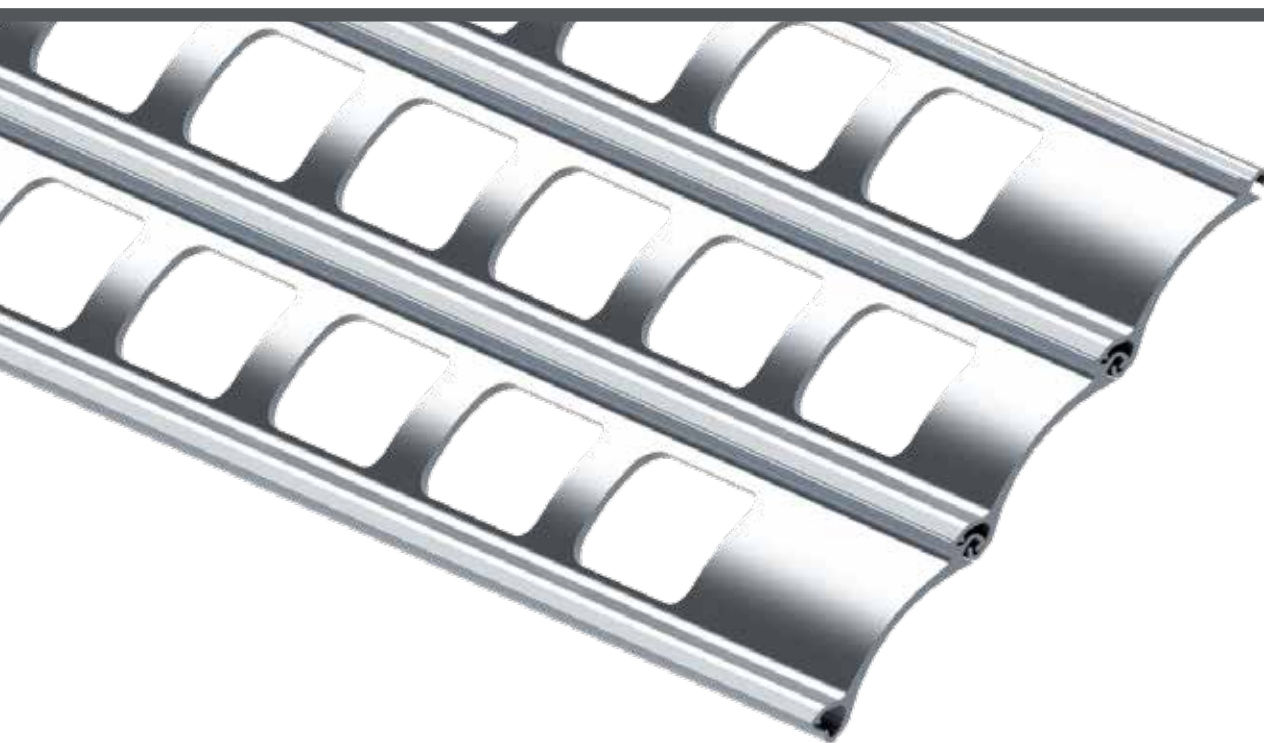

ALUMINIUM „RECTANGULAR” ROLLING GRILLE

Copyright notice and disclaimer.

The drawings included in the data sheet are for illustration only. The manufacturer reserves the right to change design and materials of offered products without notice. Unauthorized copying and publishing of this document or its fragments by scanning, printing, photocopying or microfilming or in any other way without the prior consent of Krispol Sp. z o.o. is strictly prohibited. This document was prepared with the utmost care, however Krispol Sp. z o.o. shall not be liable for any damages incurred as a result of errors or omissions in the document. No rights may be derived from the content of this document.

TABLE OF CONTENTS



R2 AMP ROLLING GRILLE, SLIP-ON DRIVE p. 3 – 13



R2 AMP ROLLING GRILLE, SIDE TUBULAR DRIVE p. 14 – 21



R2 AMG ROLLING GRILLE, SPRING MECHANISM p. 22 – 29

ACCESSORIES FOR CONTROL SYSTEM p. 30 – 31

CERTIFICATIONS 32 – 39 s.

R2 AMP ROLLING GRILLE WITH SLIP-ON DRIVE

VIEW FROM INSIDE WITH INDICATED COMPONENTS

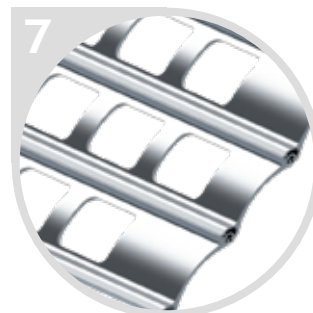
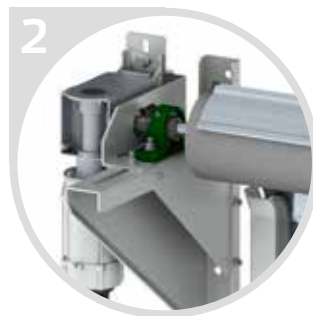

R2 AMP PRODUCT CHARACTERISTICS

SLIP-ON DRIVE

R2 AMP - PROFILES

- Aluminium, single-wall with a height of **85 mm** and a thickness of **g=3.1 mm**.
- Secured with plastic end-caps, which prevent separation of profiles.
- Openings with dimensions **83 x 52 mm**.
- Standard colour: anodized aluminium or paint in RAL colours.
- Weight: **~9 kg/m²**.

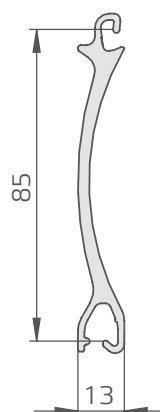

BOTTOM PANEL

- Aluminium, single-walled.
- Equipped with rubber sealing.
- Standard colour: **anodized aluminium**. Varnishing of the bottom panel with RAL colour is available on demand and charged extra.

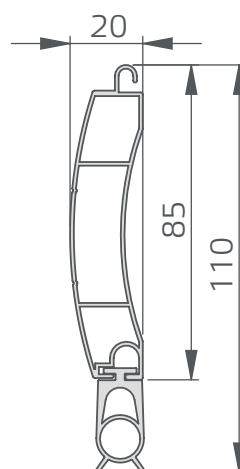

GUIDES

- Made of steel, a width of **80 mm** (aluminium - optional).
- Equipped with slides made of plastic.
- Mounting openings spaced at approx. **250 - 400 mm**, with black caps.
- Standard colour: **galvanized steel**. Painting of the guides with RAL colours is available on demand and charged extra.

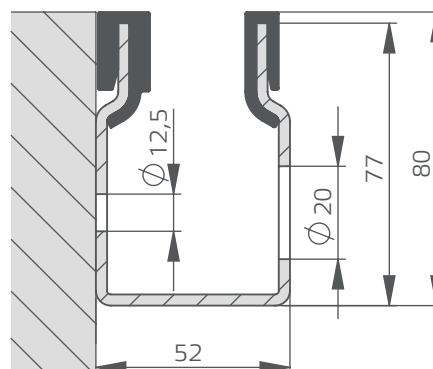

DRIVE

- **GFA SLIP-ON DRIVE**. Designed for heavily used rolling doors (R2 AMP standard).

ROLL

- Made of steel in grey colour.
- Mounted on galvanized fixed brackets.
- Vertical bearing.

CONTROL TYPES FOR R2 AMP

SLIP-ON DRIVE

TOTMANN

Totmann control mode with up/stop/down buttons. The user opens the rolling door by single pressing and releasing the „up“ button, whereas to close the door, the user must keep the „down“ button pressed until the door close.

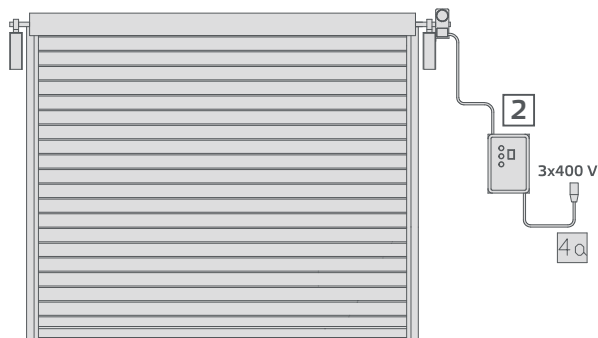

IMPULS

Control in Impuls mode (optional). It is an extended central unit with multiple configuration options.

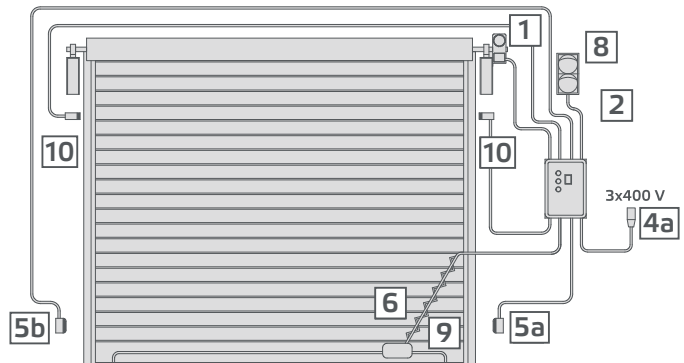

- 1 - drive / motor
- 2 - control central (TS 959 Totman, TS971/981 Impuls)
- 3a - surface-mounted, two-position key switch
- 3b - surface-mounted, single-position key switch
- 4a - power supply - 1 m cable with CEE plug (5-pin, 16 A)
- 4b - power supply - direct connection (without plug)
- 5a - (optional) photocell
- 5b - (optional) photocell (not available in case of photocell with reflex)

- 6 - spiral cable / connection box
- 7 - safety brake
- 8 - (optional) traffic light / signal lamp
- 9 - optical safety edge device
- 10 - (optional) shaft anti-winding protection

R2 AMP TECHNICAL SPECIFICATIONS

SIDE FIXED DRIVE

Maximum dimensions (width x height)	Dimension table 10 page (larger dimensions on request)
Profiles	Aluminium, single-walled, height: 85 mm, thickness: 3.1 mm
Shell weight	9 kg/m ²
Shell colour	Aluminium (varnishing in other RAL colours is available on demand and charged extra)
Drives	Slip-on drive, three-phase motor: GFA 400 V
The maximum number of cycles per hour	5 - 10 cycles per 1 h (30 cycles per 1 h - additional option)
Wind resistance class EN 12424	—
Anti-burglary class EN 1627:2011	RC3 (charged extra)
Guarantee	2 years

PARAMETERS OF DRIVES FOR R2 AMP



Slip-on drives: GFA. Designed for intensively used doors (as standard in R2 AMP)

Parameters	Motor model				
	SI 14.20	SI 17.15	SI63 25.15	SI 25.15-30.00GH	SI 40.15
Torque Nm	140	170	250	250	400
Gripping torque Nm	310	420	510	635	760
Rotational speed min ⁻¹	20	15	15	15	15
Motor power kW	0,45	0,4	0,55	1,1	0,85
Voltage V	3~240/400	3~240/400	3~240/400	3~240/400	3~240/400
Frequency Hz	50	50	50	50	50
Motor operating current A	3.4/2.0	3.7/2.2	4.0/2.3	4,5	4.4/2.6
Max. number of cycles per 1h	10	10	10	30	8
Ingress protection rating IP	65	65	65	54	65
Motor weight kg	13	16	19	33	23
Diameter of the drive shaft, mm	25	30/40	30/40	30	40

Parameters	Motor model			
	SI 55.15	SI 75.15	SI 100.10	SI 140.7
Torque Nm	550	750	1000	1400
Gripping torque Nm	1100	2800	2800	2800
Rotational speed min ⁻¹	15	15	10	7
Motor power kW	1,1	1,1	1,3	1,1
Voltage V	3~240/400	3~240/400	3~240/400	3~240/400
Frequency Hz	50	50	50	50
Motor operating current A	7.2/4.2	8.1/4.7	11.2/6.5	7.0/4.1
Max. number of cycles per 1h	8	7	6	5
Ingress protection rating IP	65	65	65	65
Motor weight kg	30	42	46	51
Diameter of the drive shaft, mm	40	55	55	55

SAFETY DEVICES WITH 'IMPULS' CONTROL

OPTICAL SENSOR FOR EDGE PROTECTION

This safety device is mounted as a standard in each rolling door and grille with automatic control (Impuls). It is active during the closing process. After detecting an obstacle, the optical edge protection generates a signal to the control panel to stop the automatic closing. The system complies with EN ISO 13849-1 standard, safety category: 2.

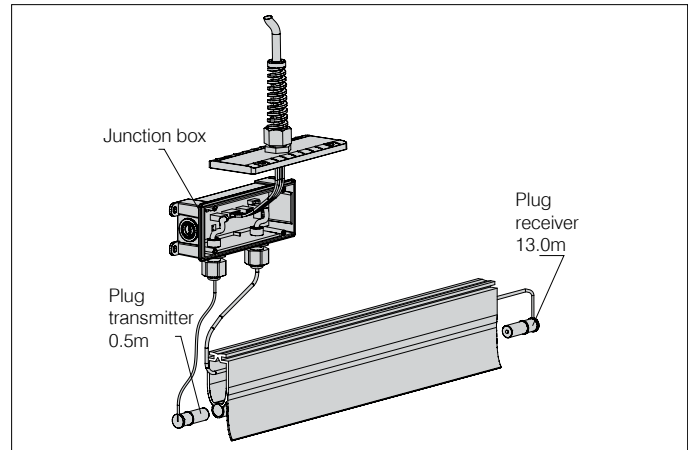

FUNCTION DESCRIPTION

The photocell transmitter generates infrared beam which is recognized by a receiver included in the set. This way a dynamic signal is identified and assessed by the control system. If the signal does get to the receiver, when the beam is interrupted for instance, STOP command is immediately sent to the control panel.

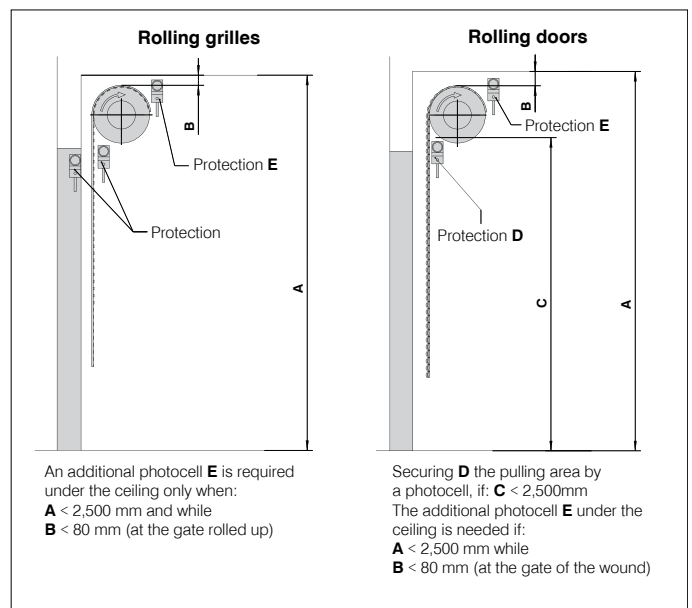

MINIMUM PROTECTION LEVELS OF THE MAIN CLOSING EDGE OF THE GATE ACCORDING TO PN-EN 12453:2017

Starting method	MINIMUM PROTECTION LEVELS OF THE MAIN CLOSING EDGE OF THE GATE ACCORDING TO PN-EN 12453:2017		
	GARAGE DOORS	INDUSTRIAL DOORS	
	Trained users (non-public area) TYPE 1	Trained users (public area) TYPE 2	Non-trained users TYPE 3
Deadman control (totmann)	A	B	Unacceptable
Impulse control with a view of the gate	C or E	C or E	C and D, or E
Impulse control without visibility of the gate	C or E	C and D, or E	C and D, or E
Automatic control (unattended)	C and D, or E	C and D, or E	C and D, or E



A – deadman control with a button.



B – deadman control with a key switch.

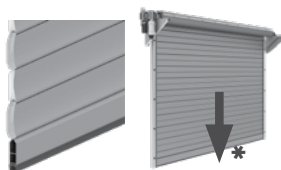

C – reduction of forces according to Annex A according to PN-EN 12453:2017 or by a pressure-sensitive equipment (PSPE or ESPE).
PSPE – pressure-sensitive protecting equipment - edge strips.
ESPE – electric-sensitive protecting equipment - edge strips.
***Amperometric force measurement** – overload sensor integrated in the motor.



D – devices that detect the presence of a person or an obstacle, present on the ground on one side of the gate, e.g. photocells.
Note! In the case of combination C + D, it is required that the device D is periodically checked at intervals of not more than six months.



E – presence-detecting devices, designed and installed to prevent any contact of a man with moving gate, e.g. radars, light grids.

EMERGENCY UNLOCKING OF R2 AMP

SLIP-ON DRIVE

Types of emergency opening of the rolling gates with the slip-on drive



Emergency opening with a crank (standard equipment)



Emergency opening with a chain (option, charged extra)

OPTIONAL PROTECTION MEASURES OF R2 AMP

SLIP-ON DRIVE

BI-DIRECTIONAL PHOTOCELL

It sends and receives a light beam reflected by the mirror. Properly aligns the door. Mounted 500mm above the floor. The wire is provided only to the transmitting photocell. Option available in Impuls version.



UNIDIRECTIONAL PHOTOCELL

It sends and receives a light beam. Properly align the door. Mounted 500mm above the floor. The wire is provided to both photocells. Option available in Impuls control version.



OPTICAL SENSORS FOR EDGE PROTECTION

Two light sensors mounted in the seal of the bottom panel. When the door encounters an obstacle during the operation, the light sensors will change its movement direction. In standard „Impuls“ control mode.



LED strips

Mounted on the bottom panel, indicate the movement of the door. May be installed inside or outside of the door. Option available in Impuls version.



SHAFT ANTI-WINDING PROTECTION

Option available in Impuls control version.

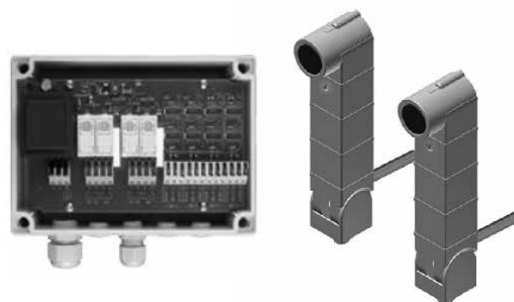

SIGNAL LAMP

Informs about door movement. Orange, pulsating light.
Option available in Impuls control version.



SIGNAL LIGHT

Signal lamp, two-colour: green and red.
Option available in Impuls control version.



ACCESSORIES FOR R2 AMP GRILLE - CHARGED EXTRA

SLIP-ON DRIVE

ACCESSORY NAME	COMMENTS
Impulse-mode operation TS 971	Optical safety edge device, control central TS 971 with RTS receiver GFA
Impulse-mode operation TS 971 XL	Optical safety edge device, control central TS 971 XL with RTS receiver GFA
Impulse-mode operation TS 981	Optical safety edge device, control central TS 981 - traffic steering
Shaft anti-winding protection H>2500	required 2 sets in the Impuls control version
Shaft anti-winding protection H<2500	required 3 sets in the Impuls control version
Emergency opening with hand chain	5 m chain in standard (working length 2,5 m)
Lock in the bottom panel	One-side access, microswitch included.
Aluminium guides	Standard colour: aluminium
Powder painting of guides in a RAL colour	RAL colours, excluding: pearl, metallic, fluorescent
Full profile	Max. 10 pcs. - larger amount on request.
Designed in „RC3“ anti-burglary class	According to EN 1627:2011 standard; Increasing the „RC“ anti-burglary class consists of adding additional security measures to the door design: strengthening its bottom panel; installing two independent locks with increased burglary resistance (2 independent locks make operation possible only from the outside; adding an extra sensor for the lock in the bottom panel to prevent door opening when the lock is in the closed position).
30-cycle-per-hour motor	SI 25.15-30,00GH motor with emergency opening with hand crank from the drive level

CONDITIONS FOR INSTALLING R2 AMP

SLIP-ON DRIVE

DIMENSIONAL TABLE																			
height\width	2250	2500	2750	3000	3250	3500	3750	4000	4250	4500	4750	5000	5250	5500	5750	6000	6250	6500	6750
2250	A																		
2375																			
2500																			
2625																			
2750																			
2875																			
3000																			
3125																			
3250																			
3375																			
3500																			
3625																			
3750																			
3875																			
4000																			
4125																			
4250																			
4375																			
4500																			
4625																			
4750																			
4875																			
5000																			
5125																			
5250																			
5375																			
5500																			

DIMENSION TABLE - RAL COATED SHELL																			
height\width	2250	2500	2750	3000	3250	3500	3750	4000	4250	4500	4750	5000	5250	5500	5750	6000	6250	6500	6750
2250	A																		
2375																			
2500																			
2625																			
2750																			
2875																			
3000																			
3125																			
3250																			
3375																			
3500																			
3625																			
3750																			
3875																			
4000																			
4125																			
4250																			
4375																			
4500																			
4625																			
4750																			
4875																			
5000																			
5125																			
5250																			
5375																			
5500																			

POSSIBILITY TO USE THE 30-CYCLE-PER-HOUR MOTOR																			
height\width	2250	2500	2750	3000	3250	3500	3750	4000	4250	4500	4750	5000	5250	5500	5750	6000	6250	6500	6750
2250	<div style="display: flex; justify-content: space-between; align-items: center;"> <div style="width: 40%;">YES</div> <div style="width: 20%;"></div> <div style="width: 40%; text-align: right;">NO</div> </div>																		
2375																			
2500																			
2625																			
2750																			
2875																			
3000																			
3125																			
3250																			
3375																			
3500																			
3625																			
3750																			
3875																			
4000																			
4125																			
4250																			
4375																			
4500																			
4625																			
4750																			
4875																			
5000																			
5125																			
5250																			
5375																			
5500																			

CONDITIONS FOR INSTALLING R2 AMP

SLIP-ON DRIVE

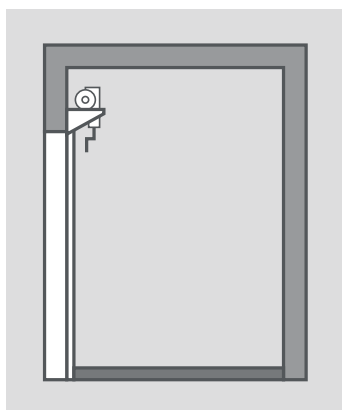

B_{max}	=	6750 mm
b_{min}	=	90 mm
bk_{min}	=	270 mm
bn_{min}	=	400 mm
H_{max}	=	5500 mm
W_{min}	=	550 mm
H_p	=	H

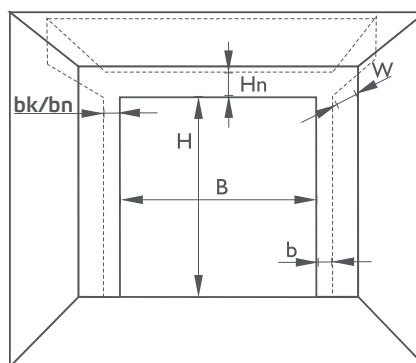

measuring method, view from the inside

- B** - opening width
- b** - width of jambs
- bk** - jamb width on the console
- bn** - jamb width for the height of console with drive
- H** - opening height
- Hn** - lintel height
- Hp** - passage height
- W** - installation depth
- Wn** - installation depth from the drive side

SLIP-ON DRIVES COVER

DOORS R1 SDP, R1 ADP, R1 SSP, R1 ASP | KRATY R2 SSP, R2 SCP, R2 SPP, R2 APP, R2 AMP

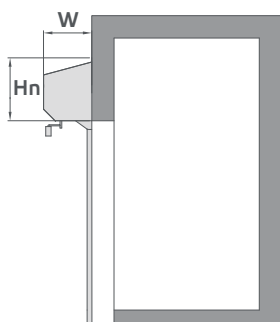

Shaft cover size	
A	
bk min	400 mm
bn min	620 mm
Hn min	820 mm
W min	550 mm

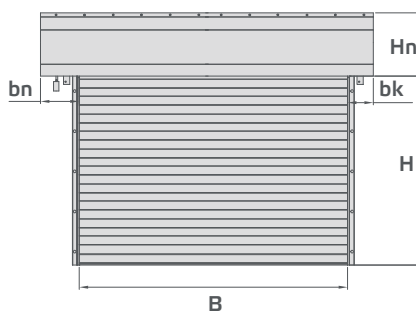

- bk** - sideroom width at the height of console
- bn** - sideroom width at the height of console with drive
- Hn** - lintel height
- W** - building-in depth



ARCHITECTURAL BASE FOR R2 AMP

SLIP-ON DRIVE

Base structure prepared for rolling door with dimensions of 3000x2700 mm, other door dimensions should be calculated analogously, selecting parameter values from the table.

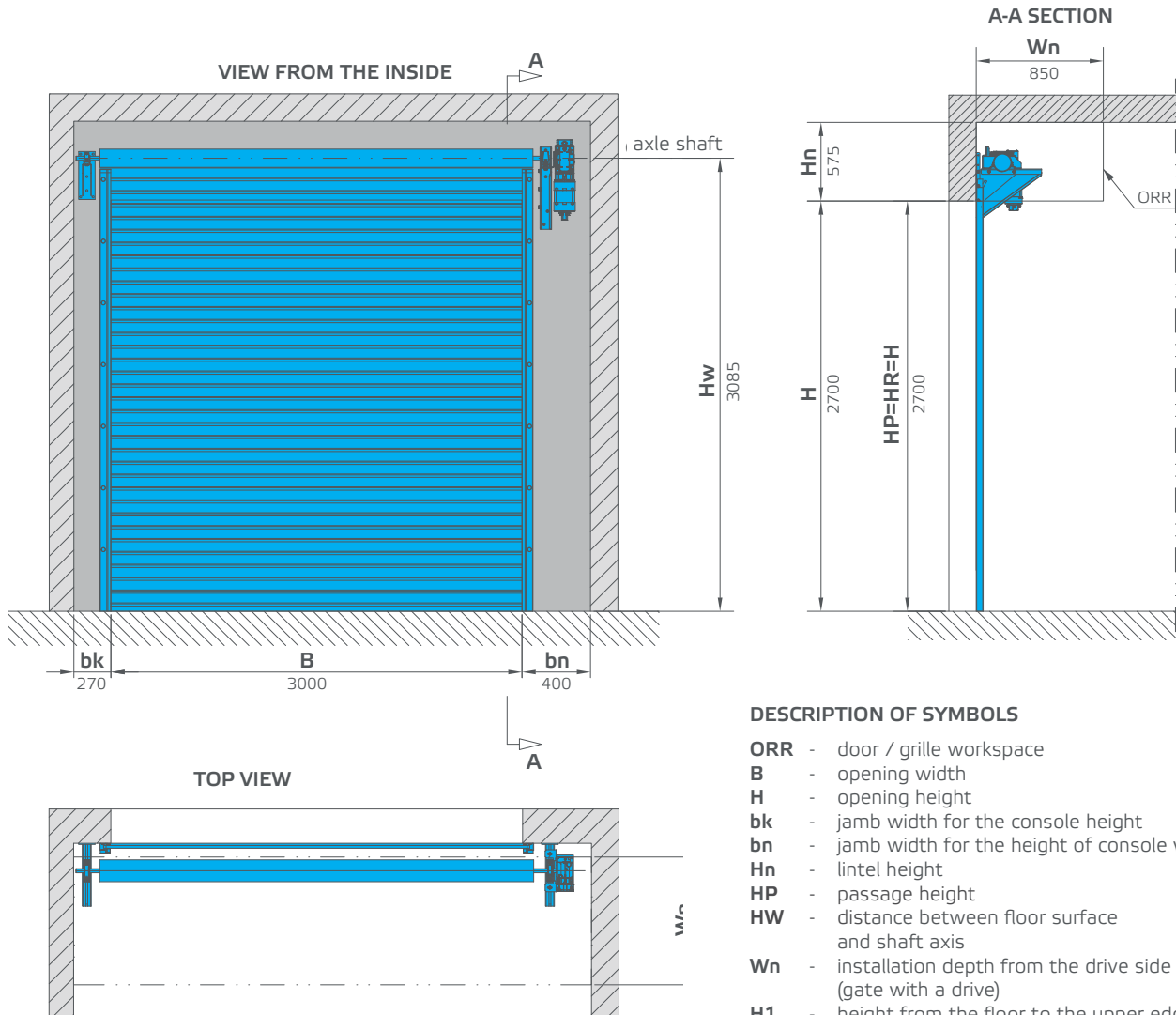

DESCRIPTION OF SYMBOLS

- ORR** - door / grille workspace
- B** - opening width
- H** - opening height
- bk** - jamb width for the console height
- bn** - jamb width for the height of console with drive
- Hn** - lintel height
- HP** - passage height
- HW** - distance between floor surface and shaft axis
- Wn** - installation depth from the drive side (gate with a drive)
- H1** - height from the floor to the upper edge of the load-bearing structure
- Q** - rolling door weight [kg]
- P** - gate shell area [m²]

SELECTION PARAMETERS FOR R2 AMP								
Symbol	Outline dimensions [mm]							Door dimensions in the figure [mm]
	R2 AMP							R2 AMP
	B (B ≤ 6000)			B (B > 6000)				
	Hn	Wn	Q [kg]	Hn	Wn	Q [kg]		
H	(max. 3000)	min. 575	850	max. 420	min. 620	850	max. 845	H=2700
	(max. 5000)	min. 630	850	max. 595	min. 680	850	max. 1270	Hn=575
	(max. 5500)	min. 650	850	max. 765	min. 700	850	max. 1370	Wn=850
bn	min. 400							bn=400
bk	min. 270							bk=270
HP=HR	H							HP=HR=H
H1	H + min. Hn							H1=3275

CONSTRUCTION BASE OF R2 AMP

SLIP-ON DRIVE

Base structure prepared for rolling door with dimensions of 3000x2700 mm, other door dimensions should be calculated analogously, selecting parameter values from the table.

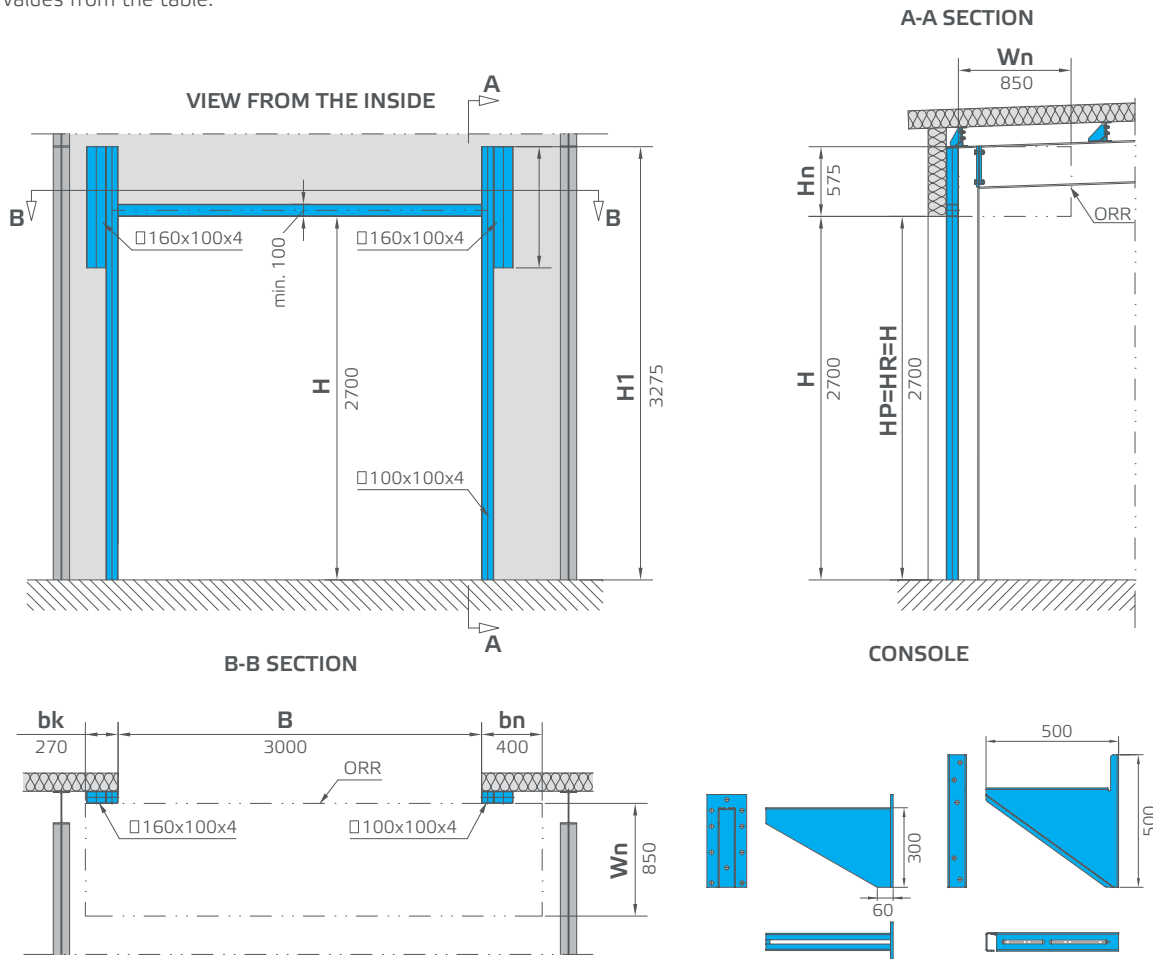

DESCRIPTION OF SYMBOLS

- | | |
|---|--|
| ORR - door / grille workspace | H2 - height from the floor to the lower edge of the console bracket |
| B - opening width | Hn - lintel height |
| H - opening height | HP - passage height |
| bk - jamb width for the console height | HR - operating height |
| bn - jamb width for the height of console with drive | Wn - installation depth from the drive side |
| Q - rolling door / grille weight [kg] | |
| H1 - height from the floor to the upper edge of the load-bearing structure | |

SELECTION PARAMETERS FOR R2 AMP								
Symbol	Outline dimensions [mm]							Door dimensions in the figure [mm]
	R2 AMP							R2 AMP
	B (B ≤ 6000)			B (B > 6000)				
	Hn	Wn	Q [kg]	Hn	Wn	Q [kg]		
H	(max. 3000)	min. 575	850	max. 420	min. 620	850	max. 845	H=2700
	(max. 5000)	min. 630	850	max. 595	min. 680	850	max. 1270	Hn=575
	(max. 5500)	min. 650	850	max. 765	min. 700	850	max. 1370	Wn=850
bn	min. 400							bn=400
bk	min. 270							bk=270
HP=HR	H							HP=HR=H
H1	H + min. Hn							H1=3275
H2	H - 400							H2=2300

R2 AMP ROLLING GRILLE WITH SIDE TUBULAR DRIVE

VIEW FROM INSIDE WITH INDICATED COMPONENTS

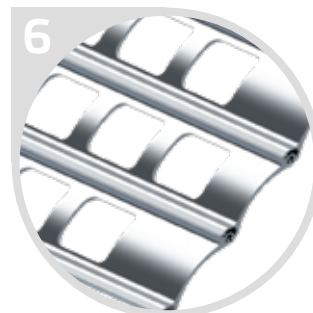

R2 SSP PRODUCT CHARACTERISTICS

SIDE TUBULAR DRIVE

R2 AMP – PROFILE

- Aluminium, single-wall with a height of **85 mm** and a thickness of **g=3.1 mm**.
- Secured with plastic end-caps, which prevent separation of profiles.
- Openings with dimensions **83 x 52 mm**.
- Standard colour: anodized aluminium or paint in RAL colours.
- Weight: **~9 kg/m²**.

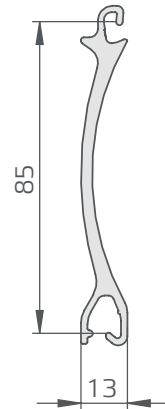

BOTTOM PANEL

- Aluminium, single-walled.
- Equipped with rubber sealing.
- Standard colour: **anodized aluminium**. Painting in selected RAL colour is available on demand and charged extra.

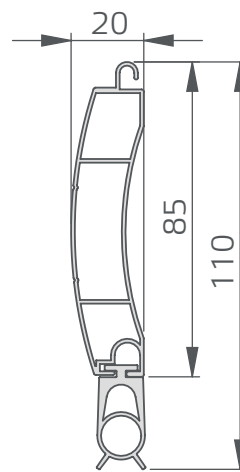

GUIDES

- Steel with a width of **80 mm**.
- Equipped with slides made of plastic.
- Mounting holes spaced by approx. **250 - 400 mm**, with black caps.
- Standard colour: **galvanized steel**. Painting of the guides with RAL colours is available on demand and charged extra.

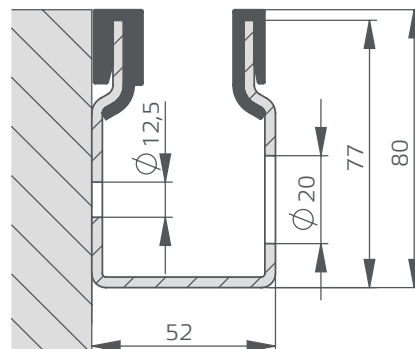

DRIVE

- Side tubular drive. Considerably reduces required installation space.

ROLL

- Made of steel in grey colour.
- Mounted on galvanized fixed brackets.
- Vertical bearing.

CONTROL TYPES FOR R2 AMP

SIDE TUBULAR DRIVE

TOTMANN

Totmann control mode is operated with a key switch. The door is opened by turning the key in the adequate direction.

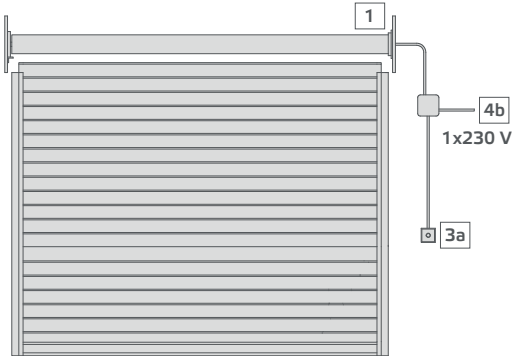

IMPULS

Control in Impuls mode (optional). It is an extended central unit with multiple configuration options.

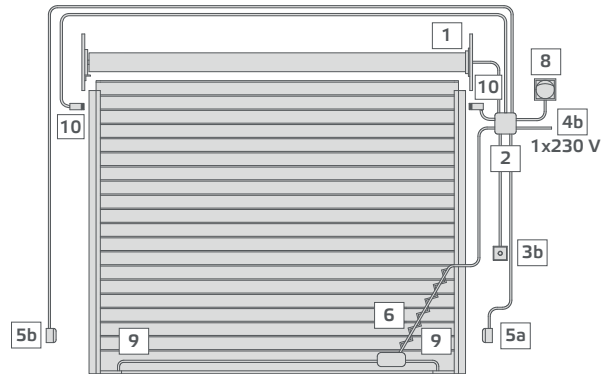

- 1 - gear-motor
- 2 - control unit (Rollixo Optimo Impuls)
- 3a - surface-mounted, two-position key switch
- 3b - surface-mounted, single-position key switch
- 4b - power supply – 230 V
- 5a - photocell (optional)
- 5b - photocell (optional) (not present in case of the photocell with reflector)
- 6 - spiral cable/junction box
- 8 - signal/warning lamp (optional)
- 9 - optical sensors for edge protection
- 10 - shaft anti-winding protection

R2 AMP TECHNICAL SPECIFICATIONS

SIDE TUBULAR DRIVE

Maximum dimensions (width x height)	Dimension table 20 page
Profiles	Aluminium, single-walled, height: 91 mm, thickness: 1.25 mm
Shell weight	9 kg/m ²
Shell colour	Aluminium (painting in other RAL colours is available on demand and charged extra)
Drives	Side tubular drive 230 V
Opening speed	~0,12 m/s (the speed depends on the shaft diameter and rotational speed of the motor)
Closing speed	~0,12 m/s (the speed depends on the shaft diameter and rotational speed of the motor)
The maximum number of cycles per day	10 cycles per day (maximum time of continuous motor operation: 4 min)
Wind resistance class EN 12424	—
Anti-burglary class EN 1627:2011	RC3 (charged extra)
Guarantee	2 years

PARAMETERS OF SIDE TUBULAR DRIVES FOR R2 AMP ROLLING GRILLES

	Side tubular drive (optional for R2 AMP rolling door, no extra charge). Considerably reduces required installation space.			
	Motor model			
Parameters	T8S DMI 150	T8S DMI 200	T8S DMI 250	T8S DMI 300
Torque Nm	150	200	250	300
Max. number of revolutions in one direction	17	17	17	17
Rotational speed min ⁻¹	8	8	8	8
Max. shell weight kg	156	208	259	311
Motor power kW	450	710	710	855
Voltage V	230	230	230	230
Frequency Hz	50	50	50	50
Control voltage V	230	230	230	230
Motor operating current A	2	2,5	3,2	3,9
Ingress protection rating IP	44	44	44	44
Ambient operational temperature range °C	-20/+60	-20/+60	-20/+60	-20/+60
Motor weight kg	11	12,5	13	13,5
Diameter of the drive shaft, mm	133	133	133	133

EMERGENCY UNLOCKING OF R2 AMP

SIDE TUBULAR DRIVE

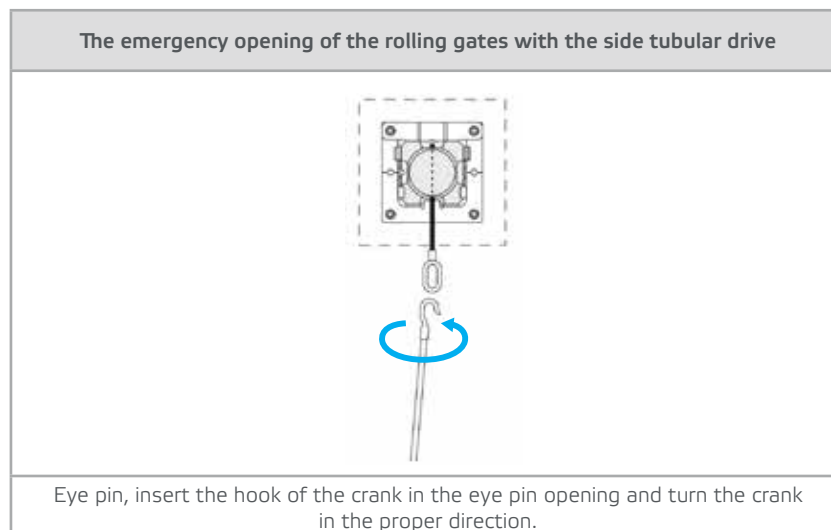

OPTIONAL PROTECTION MEASURES OF R2 AMP

SIDE TUBULAR DRIVE

BI-DIRECTIONAL PHOTOCELL

It sends and receives a light beam reflected by the mirror. Properly aligns the door. Mounted 500mm above the floor. The wire is provided only to the transmitting photocell. Option available in Impuls version.



UNIDIRECTIONAL PHOTOCELL

It sends and receives a light beam. Properly align the door.
Mounted 500mm above the floor. The wire is provided to both photocells.
Option available in Impuls control version.



OPTICAL SENSORS FOR EDGE PROTECTION

Two light sensors mounted in the seal of the bottom panel.
When the door encounters an obstacle during the operation the light sensors will change its movement direction. In standard „Impuls“ control mode.



SHAFT ANTI-WINDING PROTECTION

Option available in Impuls control version.

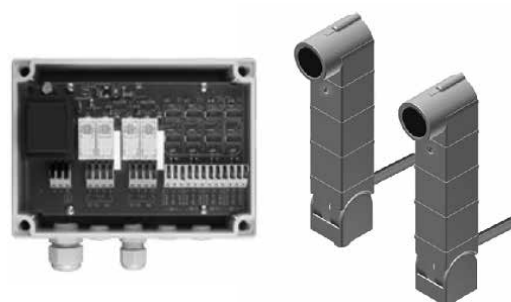

SIGNAL LAMP

Informs about door movement. Orange, pulsating light.
Option available in Impuls control version.



ACCESSORIES FOR R2 AMP GRILLE - CHARGED EXTRA SIDE TUBULAR DRIVE

ACCESSORY NAME	COMMENTS
Control in Impuls mode	Somfy ROLLIXO OPTIMO panel with built-in RTS receiver, optical safety edge device, 5 m cable
Shaft anti-winding protection H>2500	required 2 sets in the Impuls control version
Shaft anti-winding protection H<2500	required 3 sets in the Impuls control version
Lock in the bottom panel	One-side access, microswitch included.
Aluminium guide	standard colour: aluminium
Varnishing of guides in a RAL colour	RAL colours, excluding: pearl, metallic, fluorescent
Full profile	max. 10 pcs. - larger amount on request.
Designed in „RC3“ anti-burglary class	According to EN 1627:2011 standard; Increasing the „RC“ anti-burglary class consists of adding additional security measures to the door design: strengthening its bottom panel; installing two independent locks with increased burglary resistance (2 independent locks make operation possible only from the outside; adding an extra sensor for the lock in the bottom panel to prevent door opening when the lock is in the closed position).

CONDITIONS FOR INSTALLING R2 AMP

SIDE TUBULAR DRIVE

DIMENSIONAL TABLE - ANODIZED SHELL																
height\width	2250	2500	2750	3000	3250	3500	3750	4000	4250	4500	4750	5000	5250	5500	5750	6000
2250	A															
2375																
2500																
2625																
2750																
2875																
3000																
3125																
3250																
3375																
3500																
3625																
3750																
3875																
4000																
4125																
4250																
4375																
4500																
4625																
4750																
4875																
5000																

DIMENSIONAL TABLE - RAL COATED SHELL																
height\width	2250	2500	2750	3000	3250	3500	3750	4000	4250	4500	4750	5000	5250	5500	5750	6000
2250	A															
2375																
2500																
2625																
2750																
2875																
3000																
3125																
3250																
3375																
3500																
3625																
3750																
3875																
4000																
4125																
4250																
4375																
4500																
4625																
4750																
4875																
5000																

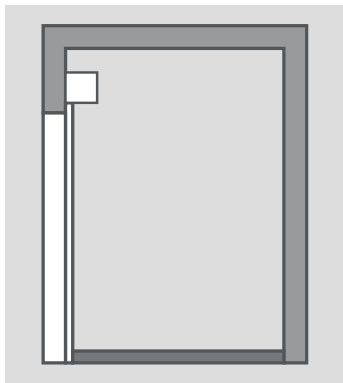

- B_{max} = 6000 mm
- b_{min} = 90 mm
- bn/bk_{min} = 140 mm
- H_{max} = 5000 mm
- W_{min} = 330 mm
- H_p = H
- Hn_{min} = 500 / 570 mm

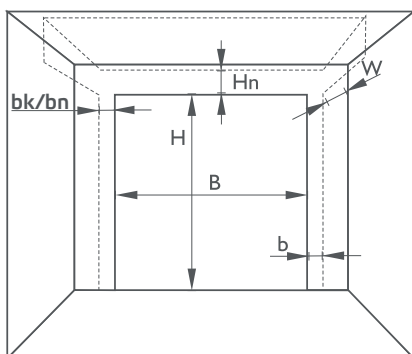

measuring method, view from the inside

- B** - opening width
- b** - width of jambs
- bk** - jamb width on the console
- bn** - jamb width for the height of console with drive
- H** - opening height
- Hn** - lintel height
- Hp** - passage height
- W** - installation depth
- Wn** - installation depth from the drive side

FOUNDATION ARCHITECTURAL R2 AMP

SIDE TUBULAR DRIVE

Base structure prepared for rolling door with dimensions of 3000x3000 mm, other door dimensions should be calculated analogously, selecting parameter values from the table.

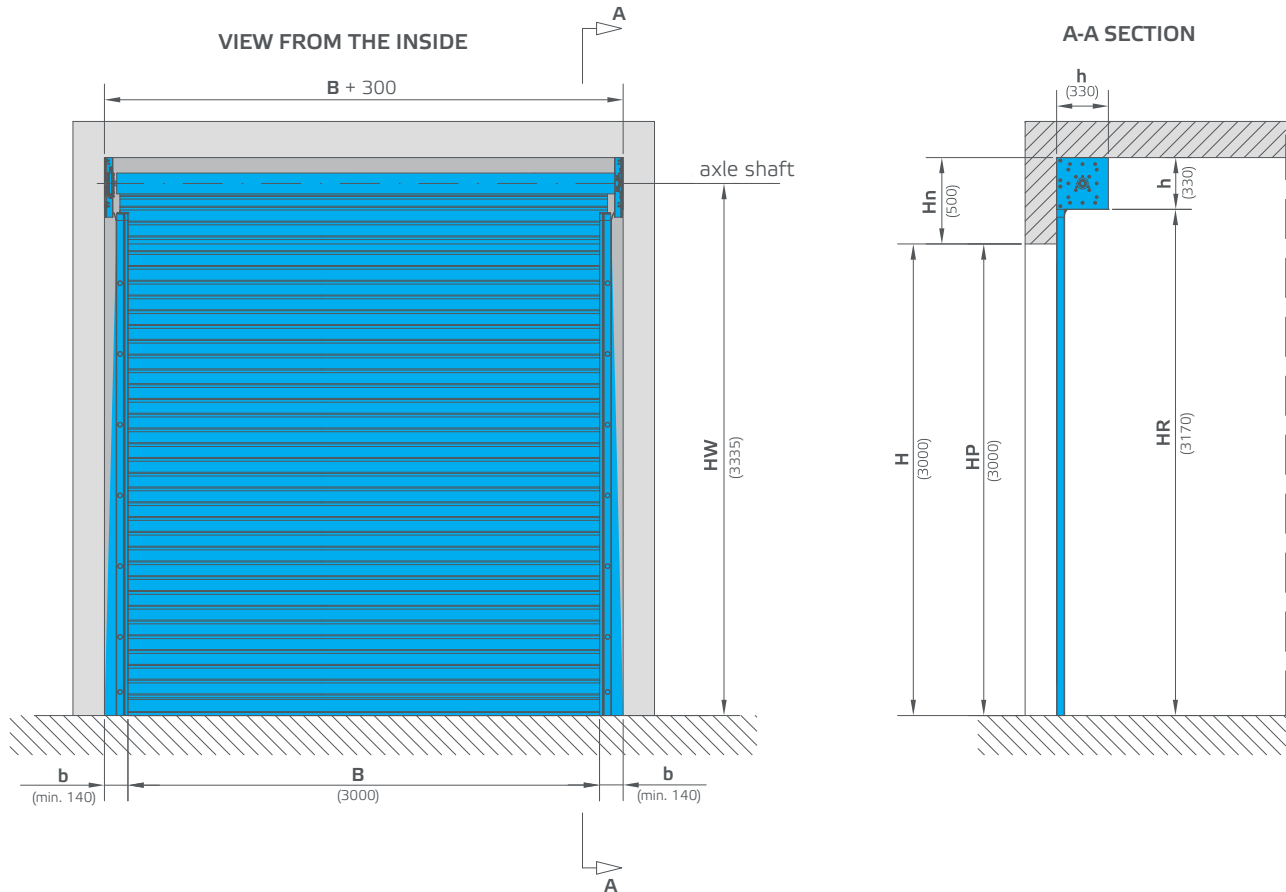

DESCRIPTION OF SYMBOLS

- ORR** - door / grille workspace
- B** - opening width
- H** - opening height
- b** - width of jambs
- bn** - jamb width for the height of console with drive
- h** - height of the side board
- Hn** - lintel height
- HP** - passage height

- HR** - operating height
- HW** - height from the floor to the shaft axis
- Wn** - installation depth from the drive side
- Q** - rolling door / grille weight [kg]

Symbol	Outline dimensions [mm]	Door dimensions in the figure [mm]
B	6000	3000
H	5000	3000
Hn	500	500
Q	max. 300 [kg]	260 [kg]
b	min. 140	140
Wn	330	330
HP	H	3000
HR	H+170	3170
HW	H+335	3335
H1	H+hn	3500

CONSTRUCTION BASE OF R2 AMP

SIDE TUBULAR DRIVE

Base structure prepared for rolling door with dimensions of 3000x3000 mm, other door dimensions should be calculated analogously, selecting parameter values from the table.

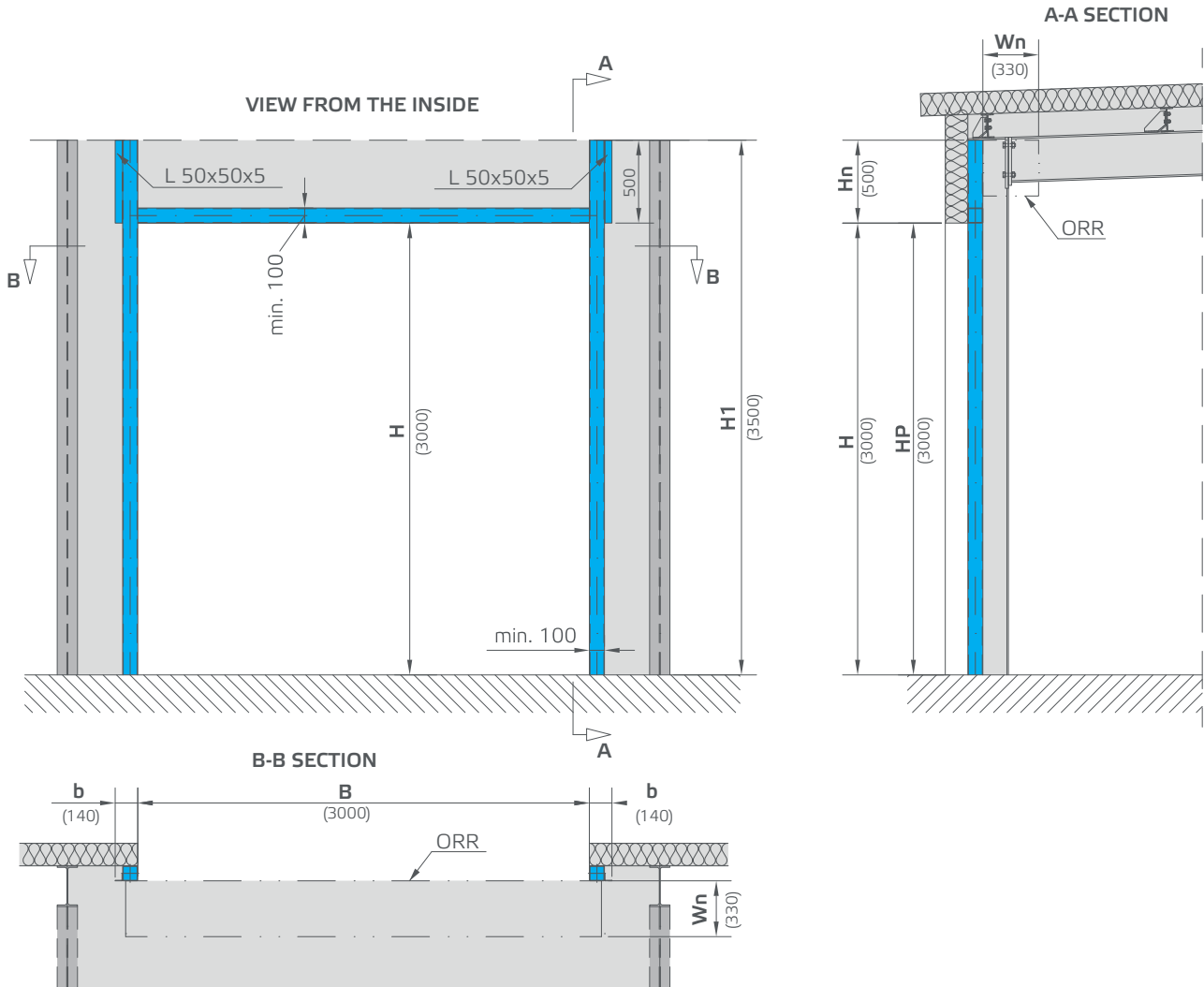

OPIS SYMBOLI

ORR - door / grille workspace

B - opening width

H - opening height

b - width of jambs

bn - jamb width for the height of console with drive

h - height of the side board

Hn - lintel height

HP - passage height

HR - operating height

HW - height from the floor to the shaft axis

Wn - installation depth from the drive side

Q - rolling door / grille weight [kg]

Symbol	Outline dimensions [mm]	Door dimensions in the figure [mm]
B	6000	3000
H	5000	3000
Hn	500	500
Q	max. 300 [kg]	260 [kg]
b	min. 140	140
Wn	330	330
HP	H	3000
HR	H+170	3170
HW	H+335	3335
H1	H+h	3500

R2 AMG ROLLING DOOR WITH CENTRAL DRIVE

VIEW FROM INSIDE WITH INDICATED COMPONENTS

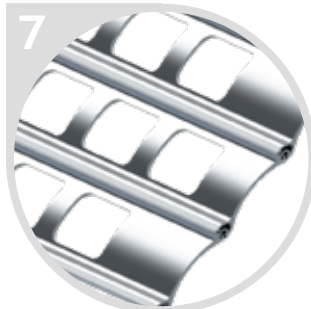

*OPTIONAL

R2 AMG PRODUCT CHARACTERISTICS

R2 AMG – PROFILES

- Aluminium, single-wall with a height of **85 mm** and a thickness of **g=3.1 mm**.
- Secured with plastic end-caps, which prevent separation of profiles.
- Openings with dimensions **83 x 52 mm**.
- Standard colour: anodized aluminium or paint in RAL colours.
- Weight: **~9 kg/m²**.

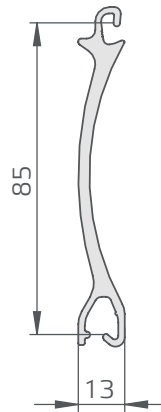

BOTTOM PANEL

- Aluminium, single-walled.
- Equipped with rubber sealing.
- Standard colour: **anodized aluminium**. Painting the shell in selected RAL colour is available on demand and charged extra.

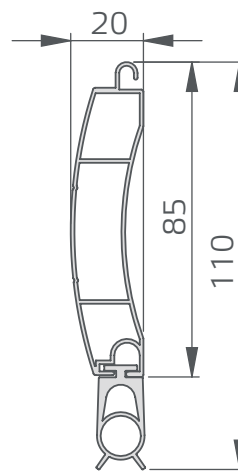

GUIDES

- Steel with a width of **80 mm**.
- Aluminium with a width of **80 mm** (charged extra).
- Equipped with slides made of plastic.
- Mounting holes spaced by approx. **250 - 400 m**, with black caps.
- Standard colour: **galvanized steel**. Painting of the guides with RAL colours is available on demand and charged extra.

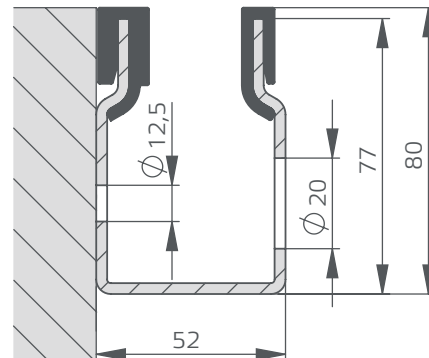

DRIVE

- Spring mechanism in the rolling grilles of **R2 AMG** type, without motor in the standard version - the springs act as a counterweight. Opening and closing is carried out manually. A central motor may be installed on the shaft (optional).

ROLL

- Made of steel in grey colour.
- Mounted on galvanized fixed brackets.
- Vertical bearing.

CONTROL TYPES FOR R2 AMG

(APPLIES TO THE VERSION WITH THE MOTOR DRIVE)

TOTMANN

Totmann control mode is operated with a key switch.
The door is opened by turning the key in the adequate direction.

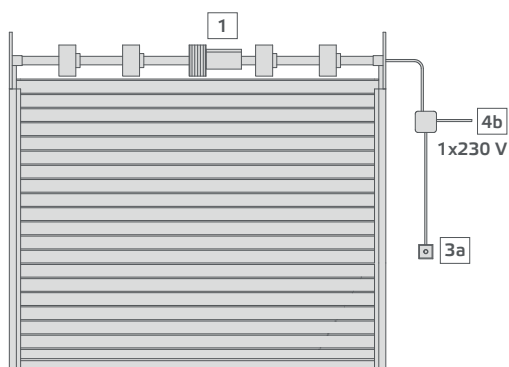

IMPULS

Control in Impuls mode (optional). It is an extended central unit with multiple configuration options.

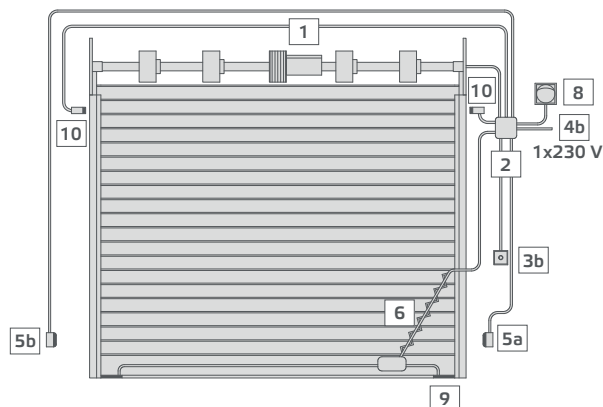

- 1 - gear-motor
- 2 - control unit (Rollixo Optimo Impuls)
- 3a - surface-mounted, two-position key switch
- 3b - surface-mounted, single-position key switch
- 4b - power supply – 230 V
- 5a - photocell (optional)
- 5b - photocell (optional) (not present in case of the photocell with reflector)
- 6 - spiral cable / junction box
- 8 - signal/warning lamp (optional)
- 9 - optical sensors for edge protection
- 10 - shaft anti-winding protection

R2 AMG TECHNICAL SPECIFICATIONS

WITH SPRING MECHANISM (PLANETARY MOTOR - OPTIONAL)

Maximum dimensions (width x height)	Dimension table 28 page
Profiles	Aluminium, single-walled, height: 85 mm, thickness: 1.25 mm
Shell weight	9 kg/m ²
Shell colour	Aluminium (painting in other RAL colours is available on demand and charged extra)
Drive	Spring mechanism for manual operation, the central motor 230 V (optional)
Opening speed	~0,14 m/s (the speed depends on the shaft diameter and rotational speed of the motor)
Closing speed	~0,14 m/s (the speed depends on the shaft diameter and rotational speed of the motor)
The maximum number of cycles per day	10 cycles per day
Wind resistance class EN 12424	—
Anti-burglary class EN 1627:2011	RC3 (charged extra)
Guarantee	2 years

PARAMETERS OF DRIVES FOR R2 AMG ROLLING GRILLES

	Planetary motor, installed in the middle of the shaft in doors with tape-spring mechanism R2 AMG	
	Motor model	
Parameters	Centris L	Centris XL
Rotational speed min ⁻¹	10	10
Max. shell weight - kg	160	140
Torque Nm	100	200
Motor power W	360	450
Voltage V	230	230
Frequency Hz	50	50
Control voltage V	230	230
Motor operating current A	1,6	2,0
The maximum area of the rolling door m ²	20	20
Shaft diameter mm	60	76
The outer diameter of the motor mm	220	240
Ingress protection rating IP	X4	X4
Ambient operational temperature range °C	-20/+60	-20/+60
Motor weight kg	6,8	7

EMERGENCY UNLOCKING OF R2 SSG

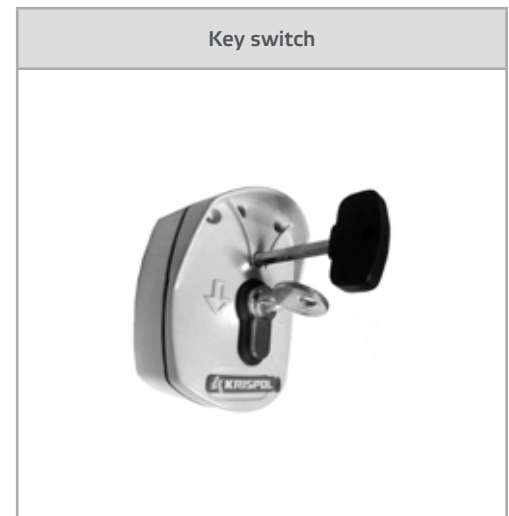
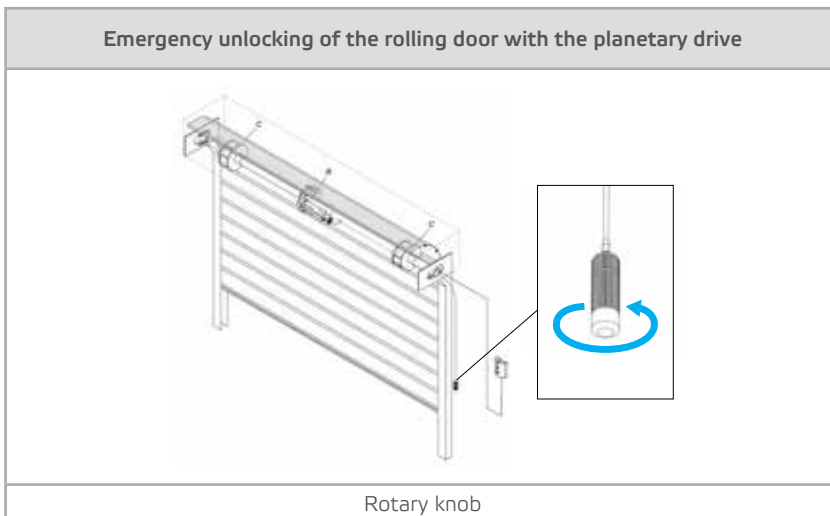

OPTIONAL PROTECTION MEASURES OF R2 AMG

UNIDIRECTIONAL PHOTOCELL

Properly align the door. Mounted 500mm above the floor. Wiring is provided to both photocells. Option available in Impuls control version.



SURFACE-MOUNTED UNIDIRECTIONAL PHOTOCELLS

Properly align the door. Mounted 500mm above the floor. Wiring is provided to both photocells. Option available in Impuls control version.



OPTICAL SENSORS FOR EDGE PROTECTION

Two light sensors mounted in the seal of the bottom panel. When the door encounters an obstacle during the operation, the light sensors will change its movement direction. In standard „Impuls“ control mode.



SHAFT ANTI-WINDING PROTECTION

Option available in Impuls control version.

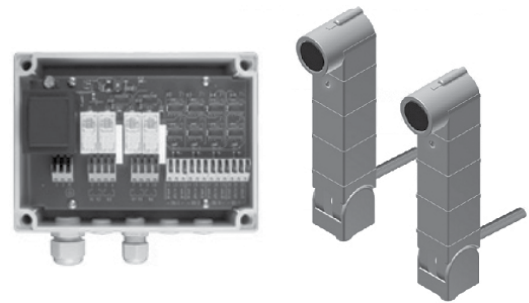

SIGNAL LAMP

Informs about door movement. Orange, pulsating light. Option available in Impuls control version.



ACCESSORIES FOR R2 AMG ROLLING GRILLE - CHARGED EXTRA

ACCESSORY NAME	COMMENTS
Electric drive (1x230V) with Totmann control mode	Two-position key switch (surface-mounted), 5 m cable, lock micro-switch.
Electric drive (1x230V) with „Impuls“ control mode	Somfy ROLLIXO OPTIMO panel with built-in RTS receiver, optical safety edge device, single-position key switch (surface-mounted), 5 m cable, lock micro-switch.
Shaft anti-winding protection H>2500	required 2 sets in the Impuls control version
Shaft anti-winding protection H<2500	required 3 sets in the Impuls control version
Aluminium guides	standard colour: aluminium
Powder painting of guides in RAL colours	RAL colours, excluding: pearl, metallic, fluorescent
Full profile	max. 10 pcs. - larger amount on request.
Designed in „RC3“ anti-burglary class	According to EN 1627:2011 standard; Increasing the „RC“ anti-burglary class consists of adding additional security measures to the door design: strengthening its bottom panel; installing two independent locks with increased burglary resistance (2 independent locks make operation possible only from the outside; adding an extra sensor for the lock in the bottom panel to prevent door opening when the lock is in the closed position).

CONDITIONS FOR INSTALLING R2 AMG

		DIMENSIONAL TABLE												
side board (h)	height\width	1500	1750	2000	2250	2500	2750	3000	3250	3500	3750	4000	4250	4500
340	1500													
	1625													
	1750													
	1875													
	2000													
370	2125													
	2250													
	2375													
	2500													
	2625													
	2750													
	2875													
	3000													
400	3125													
	3250													
	3375													
	3500													
	3625													
	3750													
	3875													
	4000													

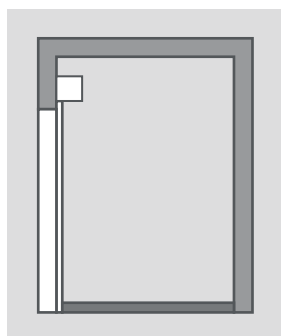

$$\begin{aligned}
 B_{\max} &= 4500 \text{ mm} \\
 b_{\min} &= 100 \text{ mm} \\
 H_{\min} &= h + 100 \text{ mm} \\
 W &= h \\
 H_p &= H - 120 \text{ mm} \\
 H_{\max} &= 4000 \text{ mm}
 \end{aligned}$$

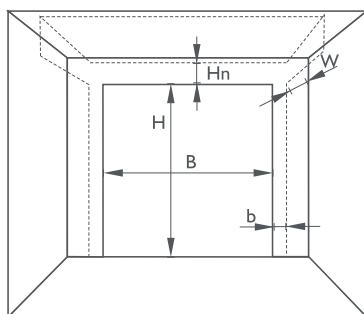

measuring method, view from the inside

- B** - opening width
- b** - width of jambs
- H** - opening height
- H_n** - lintel height
- H_p** - passage height
- W** - installation depth
- h** - height of the side board (see table)
- W_n** - installation depth from the drive side

ARCHITECTURAL BASE FOR R2 AMG

Base structure prepared for rolling door with dimensions of 3000x2500 mm, other door dimensions should be calculated analogously, selecting parameter values from the table.

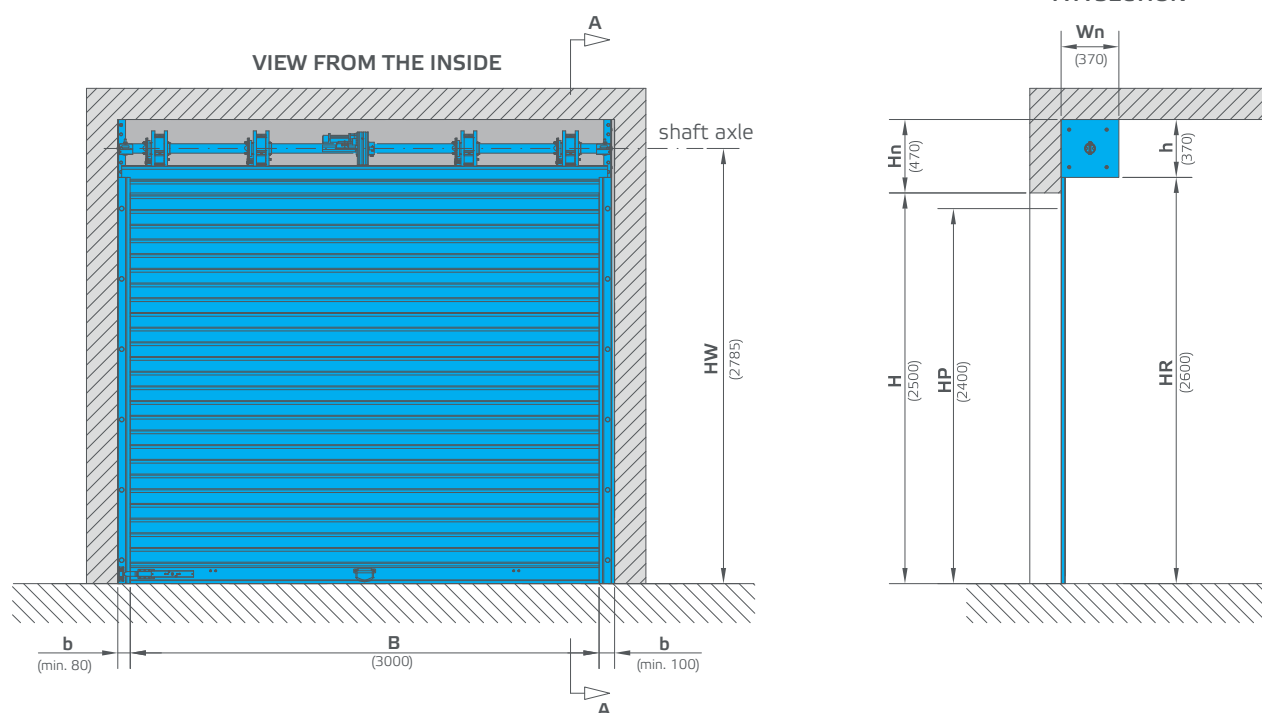

Size range for R2 AMG and height values („h“) for the side board.

H	B	
max. 1500		max. 4500
max. 2000		h=340 mm
max. 2500		h=370 mm
max. 3000		h=370 mm
max. 3500		h=400 mm
max. 4000		h=400 mm

DESCRIPTION OF SYMBOLS

- ORR** - door / grille workspace
- B** - opening width
- H** - opening height
- b** - width of jambs
- bn** - jamb width for the height of console with drive
- h** - height of the side board
- Hn** - lintel height
- HP** - passage height
- HR** - operating height
- HW** - height from the floor to the shaft axis
- Wn** - installation depth from the drive side
- Q** - rolling door / grille weight [kg]

Symbol	Outline dimensions [mm]	Door dimensions in the figure [mm]
B	max. 4500	3000
H	max. 4000	2500
Hn	min. h+100	470
Q	max. 350 [kg]	260 [kg]
b	min. 80	80
bn	min. 100	100
Wn	h	370
HP	H-100	2400
HR	H+100	2600
HW	H+100+h/2	2785
H1	H+h+100	2970

CONSTRUCTION BASE OF R2 AMG

Base structure prepared for rolling door with dimensions of 3000x2500 mm, other door dimensions should be calculated analogously, selecting parameter values from the table.

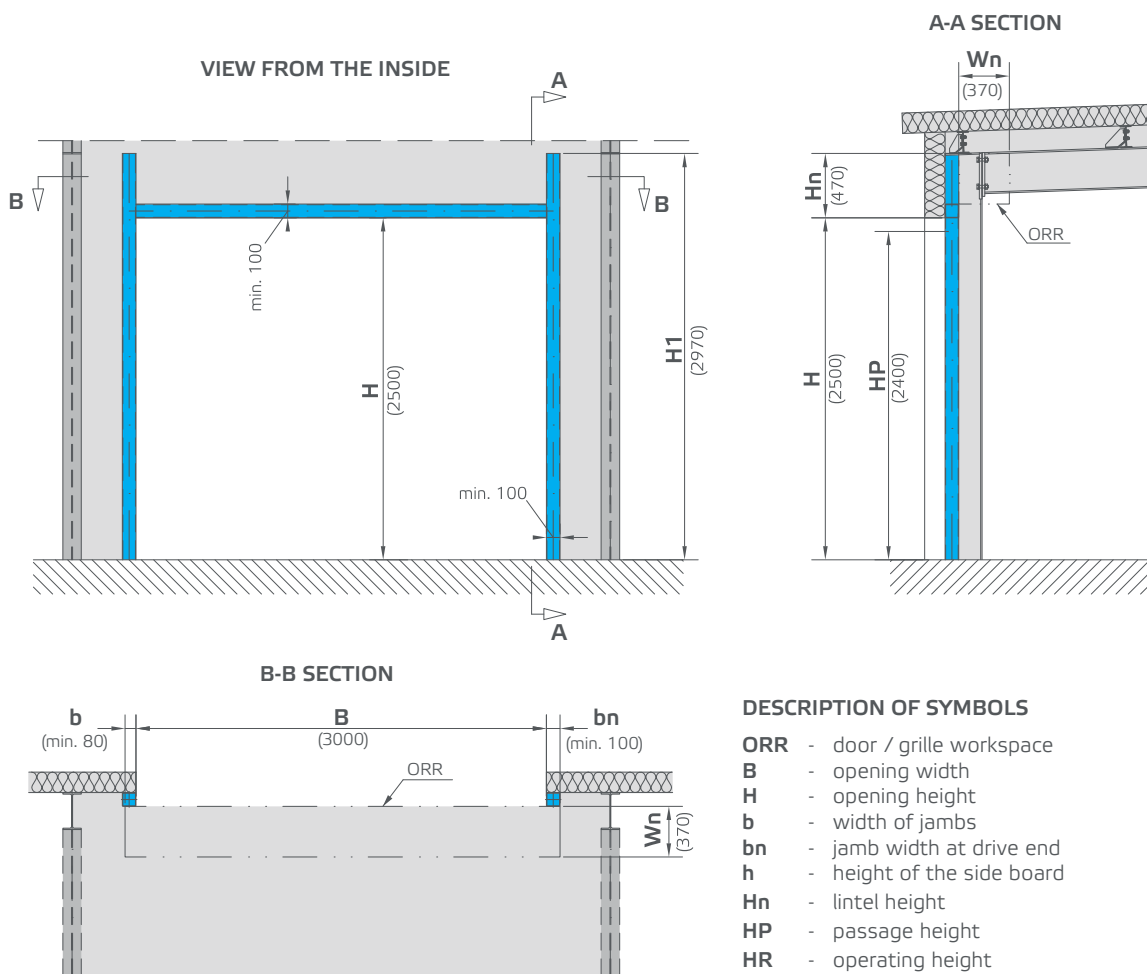

DESCRIPTION OF SYMBOLS

- ORR** - door / grille workspace
- B** - opening width
- H** - opening height
- b** - width of jambs
- bn** - jamb width at drive end
- h** - height of the side board
- Hn** - lintel height
- HP** - passage height
- HR** - operating height
- HW** - height from the floor to the shaft axis
- Wn** - installation depth from the drive side
- H1** - height from the floor to the upper edge of the load-bearing structure
- Q** - rolling door/grille weight [kg]

Symbol	Outline dimensions [mm]	Door dimensions in the figure [mm]
B	max. 4500	3000
H	max. 4000	2500
Hn	min. h+100	470
Q	max. 350 [kg]	260 [kg]
b	min. 80	80
bn	min. 100	100
Wn	h	370
HP	H-100	2400
HR	H+100	2600
HW	H+100+h/2	2785
H1	H+h+100	2970

ACCESSORIES FOR CONTROL SYSTEM

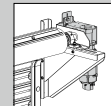

slip-on drive

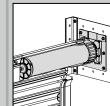

tubular side motor

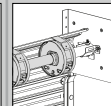

spring system with motor

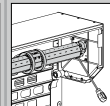

tubular motor with casing

article	name	remarks	slip-on drive		tubular side motor		spring system with motor		tubular motor with casing	
			TOTMANN	IMPULS	TOTMANN	IMPULS	TOTMANN	IMPULS	TOTMANN	IMPULS
KON.GF.001	control panel up/stop/down	without cable, IP 65	✓	✓						
KON.GF.004	control panel up/stop/down, 2 keys	without cable, IP 65	✓	✓						
XPRE.GF.001	lintel switch (pull-switch) with 2,5 m chain	without cable, IP 65		✓		✓		✓		✓
XPRE.PL.006	one-position key switch, under-plaster	without cable, IP 54, 3 keys		✓		✓		✓		✓
XPRE.PL.005	one-position key switch, on-plaster	without cable, IP 54, 3 keys		✓		✓		✓		✓
XPRE.PL.003	two-position key switch, under-plaster	without cable, IP 54, 3 keys	✓	✓	✓		✓		✓	
XPRE.PL.001	two-position key switch, on-plaster	without cable, IP 54, 3 keys	✓	✓	✓		✓		✓	
KAL.EK.002	4-wire cable with ends, 5 m	used for control panel or key/lintel switch	✓	✓	✓	✓	✓	✓	✓	✓
KAL.EK.003	4-wire cable with ends, 9 m	used for control panel or key/lintel switch	✓	✓	✓	✓	✓	✓	✓	✓
FOT.GF.001	photocell with reflex	—		✓		✓		✓		✓
FOT.GF.002	photocells, one-way	—		✓		✓		✓		✓
ODR.NI.009	2-channel receive SMX2R, universal FLOR	for max 256 transmitters		✓		✓		✓		✓
NAD.NI.012	4-channel transmitter RT20	—		✓		✓		✓		✓
NAD.GF.001	1-channel transmitter midi	—		✓		✓		✓		✓
NAD.GF.002	2-channel transmitter midi	—		✓		✓		✓		✓
NAD.GF.006	4-channel transmitter	—		✓		✓		✓		✓
LAS.PM.001	signal lamp with a handle			✓		✓		✓		✓
LAS.NI.012	signal lamp LED ERA 12/24V			✓		✓		✓		✓
LAS.NI.013	signal lamp LED ERA 230V			✓		✓		✓		✓
LAS.GF.001	signal lamp LED - red 230V	IP 65		✓		✓		✓		✓
LAS.GF.002	signal lamp LED - green 230V	IP 65		✓		✓		✓		✓
LAS.GF.003	signal lamp red/green LED	IP 65		✓						
RAD.BF.001	radar motion detector	distinguishes between persons and vehicles, direction detection, suppression of crossing traffic, setting of field size, IP 65		✓						
XLAK.PL.002	bell-type button switch, under-plaster	without cable, IP 54		✓		✓		✓		✓
AWR.PA.001	emergency drive release with integrated key switch	used in rolling doors and grills with spring system and electric drive, 2 keys					✓	✓		
FOT.KK.001	photocells, one-way Krispol	without cable		✓		✓		✓		✓
FOT.SM.001	photocells, one-way	for control central ROLLIXO OPTIMO, without cable				✓		✓		✓
NAD.SM.013	2-channel transmitter Keytis 2NS	for control central ROLLIXO OPTIMO				✓		✓		✓
NAD.SM.014	3-channel transmitter Keytis 4NS	for control central ROLLIXO OPTIMO				✓		✓		✓
NAD.SM.015	4-channel transmitter Keygo	for control central ROLLIXO OPTIMO				✓		✓		✓
MOD.WI.001	AOS 6230 processing unit security for TWIN-PRO			✓		✓		✓		✓
ZAB.WI.004	pull-in protection TWIN-PRO			✓		✓		✓		✓
	1 x LED strips 530 mm	mounted inside/outside on the bottom slat		✓		✓		✓		✓
	2 x LED strips 530 mm	mounted inside/outside on the bottom slat, max 2 parts on side		✓		✓		✓		✓
	4 x LED strips 530 mm	mounted inside/outside on the bottom slat, max 2 parts on side		✓		✓		✓		✓
KON.AH.002	reed overrun	—	✓	✓	✓	✓	✓	✓	✓	✓
STI.GF.001	plug connector (Stick)	service device, facilitating diagnostics and reviews of GFA controllers		✓		✓		✓		✓



bell-type button switch,
under-plaster
XLAK.PL.002



control panel
up/stop/down
KON.GF.001



one-position key switch,
under-plaster
XPRE.PL.006 / XPRE.PL.005



two-position key switch,
under-plaster
XPRE.PL.003 / XPRE.PL.001



emergency drive release with
integrated key switch
AWR.PA.001



reed overrun
KON.AH.002



intel switch (pull-switch)
with 2,5 m chain
XPRE.GF.001



4-channel transmitter FLO4RE
NAD.NI.012



2-channel transmitter
Keytis 2N5
NAD.SM.013



4-channel transmitter Keygo
NAD.SM.015



1-channel transmitter midi
NAD.GF.001



2-channel transmitter midi
NAD.GF.002



4-channel transmitter
NAD.GF.006



2-channel receive SMX2R,
universal FLOR
ODR.NI.009



photocells, one-way
FOT.SM.001



photocells, one-way
FOT.KK.001



photocell with refl ex
FOT.GF.001



photocells, one-way
FOT.GF.002



radar motion detector
RAD.BF.001



plug connector (Stick)
STI.GF.001



LED strip 530 mm



signal lamp with a handle
LAS.PM.001

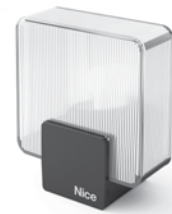

signal lamp LED ERA
LAS.NI.012 / LAS.NI.013



signal lamp, green/red LED
LAS.GF.003



pull-in protection
TWIN-PRO
ZAB.WI.004



AOS 6230 safety processing
unit for TWIN-PRO
MOD.WI.001



DECLARATION OF PERFORMANCE

04001/2021

Unique identification code of the product-type:	R2 AMP (532067/16/1)
Intended use/es:	industrial door for installation in industrial and commercial buildings
Manufacturer:	KRISPOL Sp. z o.o. ul. Michała Strzykały 4, 62-300 Września
System/s of AVCP:	3
Harmonised standard:	PN-EN 13241+A2:2016-10
Notified body:	nr 1017, TÜV SÜD CZECH s.r.o.

DECLARED PERFORMANCES

Water resistance:	Class 0	PN-EN 12425
Release of dangerous	Does not include	PN-EN 12421
Wind load resistance:	npd	PN-EN 12424
Thermal resistance (W/m² K):	npd	PN-EN 12428
Air permeability:	Class 0	PN-EN 12426
Safe opening:	Meets	PN-EN 12604
Definition of geometry of glass components:	npd	PN-EN 12604
Mechanical resistance and stability:	Meets	PN-EN 12604
Durability of water tightness, thermal resistance and air permeability against degradation:	35 000 cycles	PN-EN 12605
Operating forces:	Meets	PN-EN 12453

ADDITIONAL PROPERTIES

Low voltage directive:	Meets	2014/35/UE
Electromagnetic compatibility:	Meets	2014/30/UE
Operation with electric drive:	GFA: SI, SIK, TS959, TS971, TS982	
Resistance to manual burglary:	npd	PN-EN-1627:2011
Noise - sound insulation :		PN-EN-10140-1

The performance of the product identified above is in conformity with the set of declared performance/s. This declaration of performance is issued, in accordance with Regulation (EU) No 305/2011, under the sole responsibility of the manufacturer identified above.

Signed for and on behalf of the manufacturer by:

Grzegorz Ratajczak
at Psary Male on, 2022-03-10



EC DECLARATION OF CONFORMITY

12004/2021

Manufacturer:	KRISPOL Sp. z o.o. ul. Michała Strzykały 4, 62-300 Września	
Unique identification code of the product-type:	R2 AMP	
Product serial number:	532067/16/1	
Intended use/es:	industrial door for installation in industrial and commercial buildings	
GARAGE DOOR DIMENSIONS		
Width:	3000	mm
Height:	3000	mm
Weight:	96.81	kg
OPERATION WITH ELECTRIC DRIVE		
Control mode:	Impuls	
Gear motor type:		
Control panel type:	Control panel TS 971	
Protection:	Optical safety edge	
DECLARED CHARACTERISTICS		
Low voltage directive:	Meets	2014/35/UE
Electromagnetic compatibility:	Meets	2014/30/UE
Harmonised standard:	Meets	PN-EN 13241+A2:2016-10

The name and number of the accredited certification body or laboratory, and the certificate number or the report number of type examination, provided that the body participated in the conformity assessment of the system applied for the construction product:

The product has been tested in accordance with PN-EN 1324 + A2: 2016-10 standard by TÜV Czech Republic, Ostrava, accredited body no. 211, notified body no. 1017, which carried out the initial test of the type in system 3 and issued the PROTOCOL OF PRODUCT TYPE CONFORMITY TESTING Reg. No. 1017-CPD-162/06/02/05/0, 977/70/10/BT/AO/B, 65/70/10/BT/AO/B, 1011/70/10/BT/AO/B, 597/70/10/BT/AO/B, 1740/70/06/BT/IŻ/B, 1017-CPR-06.947.779

Signed for and on behalf of the manufacturer by:

Grzegorz Ratajczak
at Psary Male on, 2022-03-10



DECLARATION OF PERFORMANCE

04002/2021

Unique identification code of the product-type:	R2 AMP (532067/17/1)	
Intended use/es:	industrial door for installation in industrial and commercial buildings	
Manufacturer:	KRISPOL Sp. z o.o. ul. Michała Strzykały 4, 62-300 Września	
System/s of AVCP:	3	
Harmonised standard:	PN-EN 13241+A2:2016-10	
Notified body:	nr 1017, TÜV SÜD CZECH s.r.o.	
DECLARED PERFORMANCES		
Water resistance:	Class 0	PN-EN 12425
Release of dangerous	Does not include	PN-EN 12421
Wind load resistance:	npd	PN-EN 12424
Thermal resistance (W/m² K):	npd	PN-EN 12428
Air permeability:	Class 0	PN-EN 12426
Safe opening:	Meets	PN-EN 12604
Definition of geometry of glass components:	npd	PN-EN 12604
Mechanical resistance and stability:	Meets	PN-EN 12604
Durability of water tightness, thermal resistance and air permeability against degradation:	35 000 cycles	PN-EN 12605
Operating forces:	Meets	PN-EN 12453
ADDITIONAL PROPERTIES		
Low voltage directive:	Meets	2014/35/UE
Electromagnetic compatibility:	Meets	2014/30/UE
Operation with electric drive:	SIMU: T8S DMI, Somfy AXROLL/ROLLIXO OPTIMO	
Resistance to manual burglary:	npd	PN-EN-1627:2011
Noise - sound insulation :		PN-EN-10140-1

The performance of the product identified above is in conformity with the set of declared performance/s. This declaration of performance is issued, in accordance with Regulation (EU) No 305/2011, under the sole responsibility of the manufacturer identified above.

Signed for and on behalf of the manufacturer by:

Grzegorz Ratajczak
at Psary Male on, 2022-03-10



EC DECLARATION OF CONFORMITY

12004/2021

Manufacturer:	KRISPOL Sp. z o.o. ul. Michała Strzykały 4, 62-300 Września	
Unique identification code of the product-type:	R2 AMP	
Product serial number:	532067/17/1	
Intended use/es:	industrial door for installation in industrial and commercial buildings	
GARAGE DOOR DIMENSIONS		
Width:	3000	mm
Height:	3000	mm
Weight:	96.81	kg
OPERATION WITH ELECTRIC DRIVE		
Control mode:	Impuls	
Gear motor type:		
Control panel type:	Control panel Rollixo Optimo	
Protection:	Optical safety edge	
DECLARED CHARACTERISTICS		
Low voltage directive:	Meets	2014/35/UE
Electromagnetic compatibility:	Meets	2014/30/UE
Harmonised standard:	Meets	PN-EN 13241+A2:2016-10

The name and number of the accredited certification body or laboratory, and the certificate number or the report number of type examination, provided that the body participated in the conformity assessment of the system applied for the construction product:

The product has been tested in accordance with PN-EN 1324 + A2: 2016-10 standard by TÜV Czech Republic, Ostrava, accredited body no. 211, notified body no. 1017, which carried out the initial test of the type in system 3 and issued the PROTOCOL OF PRODUCT TYPE CONFORMITY TESTING Reg. No. 1017-CPD-162/06/02/05/0, 977/70/10/BT/AO/B, 65/70/10/BT/AO/B, 1011/70/10/BT/AO/B, 597/70/10/BT/AO/B, 1740/70/06/BT/IŻ/B, 1017-CPR-06.947.779

Signed for and on behalf of the manufacturer by:

Grzegorz Ratajczak
at Psary Male on, 2022-03-10



DECLARATION OF PERFORMANCE

04003/2021

Unique identification code of the product-type:	R2 AMG (532067/18/1)	
Intended use/es:	industrial door for installation in industrial and commercial buildings	
Manufacturer:	KRISPOL Sp. z o.o. ul. Michała Strzykały 4, 62-300 Września	
System/s of AVCP:	3	
Harmonised standard:	PN-EN 13241+A2:2016-10	
Notified body:	nr 1017, TÜV SÜD CZECH s.r.o.	
DECLARED PERFORMANCES		
Water resistance:	Class 0	PN-EN 12425
Release of dangerous	Does not include	PN-EN 12421
Wind load resistance:	npd	PN-EN 12424
Thermal resistance (W/m² K):	npd	PN-EN 12428
Air permeability:	Class 0	PN-EN 12426
Safe opening:	Meets	PN-EN 12604
Definition of geometry of glass components:	npd	PN-EN 12604
Mechanical resistance and stability:	Meets	PN-EN 12604
Durability of water tightness, thermal resistance and air permeability against degradation:	35 000 cycles	PN-EN 12605
Operating forces:	Meets	PN-EN 12453
ADDITIONAL PROPERTIES		
Low voltage directive:	Meets	2014/35/UE
Electromagnetic compatibility:	Meets	2014/30/UE
Operation with electric drive:	-	
Resistance to manual burglary:	npd	PN-EN-1627:2011
Noise - sound insulation :		PN-EN-10140-1

The performance of the product identified above is in conformity with the set of declared performance/s. This declaration of performance is issued, in accordance with Regulation (EU) No 305/2011, under the sole responsibility of the manufacturer identified above.

Signed for and on behalf of the manufacturer by:

Grzegorz Ratajczak
at Psary Male on, 2022-03-10



322/612/353/2021

Gdańsk, 12-10-2021

HYGIENIC CERTIFICATE No 347/322/353/2021

1. Product (material)

**Rolling doors R1, RGZ, RGW
Rolling grilles R2**

2. Application

for installation in industrial and social utility buildings and in food industry in rooms intended for permanent stay of individuals. Developments, covers, protection of openings in residential construction for installation in cavities or on walls

3. Application institution

KRISPOL Sp. z o.o.
ul. Michała Strzykały 4
62-300 Września

4. Manufacturer

KRISPOL Sp. z o.o.
ul. Michała Strzykały 4
62-300 Września

5. The products have been assessed positively in terms of hygiene.
The approval does not cover occupational health and safety terms during the installation of the products.
6. Formal basis for issuing the approval: letter of KRISPOL Sp. z o.o. of 26-08-2021 with documentation included.
7. The present certificate may be changed or voided if either party presents sufficient evidence.
The document becomes invalid after 5 years since the date of issue or if any changes either in composition or manufacturing technology of the product have been introduced.

contact address: zts-atesty@gumed.edu.pl

KIEROWNIK
Zakładu Toksykologii Środowiska

prof. dr hab. Lidia Wolska

ZAKŁAD TOKSYKOLOGII ŚRODOWISKA

ul. Dębowa 23A, 80-204 Gdańsk | 58 349 19 36 | zts-atesty@gumed.edu.pl

	BUILDING RESEARCH INSTITUTE
  <p>AB 023</p>	GROUP OF TESTING LABORATORIES accredited by Polish Centre for Accreditation Accreditation Certificate No AB 023
LABORATORIUM OKUĆ I ŚLUSARKI BUDOWLANEJ (LOW ITB) 61-819 Poznań, ul. S. Taczaka 12 Tel. +48 61 853-76-29 Fax +48 61 853-78-33 e-mail: laboratorium@itb.poznan.pl	
EXTRACT FROM THE TEST REPORT No LOW02-1639/11/Z00OWN AND THE TECHNICAL OPINION No OWN-OT-037/2011	

Evidence of testing

The Laboratory LOW ITB carried out tests of the products:

**Steel roller „perfo” grilles of R2 SPP and R2 SPG type,
 aluminium roller „perfo” grilles of R2 APP and R2 APG type
 and aluminium roller „punched” grilles of R2 AMP and R2
 AMG type**

submitted by:

KRISPOL Sp. z o.o.
ul. Michała Strzykały 4
62-300 Września

On the basis of the Test Report and the Technical Opinion it is hereby stated that

**Steel roller grilles of R2 SPP and R2 SPG type
 and aluminium roller grilles of R2 APP, R2 APG,
 R2 AMP, R2 AMG type
 meet requirements corresponding to class 3 of
 resistance to manual burglary attempts
 according to PN-ENV 1627:2006 and PN-EN 1627:2011***

.....

Poznań, December 29th, 2011

KIEROWNIK
 Oddziału Wielkopolskiego
 Instytutu Techniki Budowlanej

.....
Mjr inż. Wojciech Kozłowski

* provided that two locking devices are used, equipped with lock cylinders corresponding to minimum key related security grade 4 and attack resistance grade 1 according to PN-EN 1303:2007 and products are equipped with elements shown in photographs in Test Report, clause 1.1

WWW.KRISPOL.DE

KRISPOL GmbH
ul. Michała Strzykały 4, 62-300 Września
tel. +48 61 662 41 00, fax +48 61 436 76 48
e-mail: info@krispol.de